

THE PERIODIC TABLE

Period 1 2 3 4 5 6 7 0 Group

1	1																		4 He Helium 2		
2	7 Li Lithium 3	9 Be Beryllium 4																		19 F Fluorine 9	20 Ne Neon 10
3	23 Na Sodium 11	24 Mg Magnesium 12																		35.5 Cl Chlorine 17	40 Ar Argon 18
4	39 K Potassium 19	40 Ca Calcium 20	45 Sc Scandium 21	48 Ti Titanium 22	51 V Vanadium 23	52 Cr Chromium 24	55 Mn Manganese 25	56 Fe Iron 26	59 Co Cobalt 27	59 Ni Nickel 28	63.5 Cu Copper 29	65 Zn Zinc 30	70 Ga Gallium 31	73 Ge Germanium 32	75 As Arsenic 33	79 Se Selenium 34	80 Br Bromine 35	84 Kr Krypton 36			
5	86 Rb Rubidium 37	88 Sr Strontium 38	89 Y Yttrium 39	91 Zr Zirconium 40	93 Nb Niobium 41	96 Mo Molybdenum 42	99 Tc Technetium 43	101 Ru Ruthenium 44	103 Rh Rhodium 45	106 Pd Palladium 46	108 Ag Silver 47	112 Cd Cadmium 48	115 In Indium 49	119 Sn Tin 50	122 Sb Antimony 51	128 Te Tellurium 52	127 I Iodine 53	131 Xe Xenon 54			
6	133 Cs Caesium 55	137 Ba Barium 56	139 La Lanthanum 57	179 Hf Hafnium 72	181 Ta Tantalum 73	184 W Tungsten 74	186 Re Rhenium 75	190 Os Osmium 76	192 Ir Iridium 77	195 Pt Platinum 78	197 Au Gold 79	201 Hg Mercury 80	204 Tl Thallium 81	207 Pb Lead 82	209 Bi Bismuth 83	210 Po Polonium 84	210 At Astatine 85	222 Rn Radon 86			
7	223 Fr Francium 87	226 Ra Radium 88	227 Ac Actinium 89																		

Key

Relative atomic mass
Symbol
Name
Atomic number



N 3 7 7 5 9 A 0 2 3 2

Leave blank

SECTION A

1. The flow diagram represents the manufacture of ammonia by the Haber process.

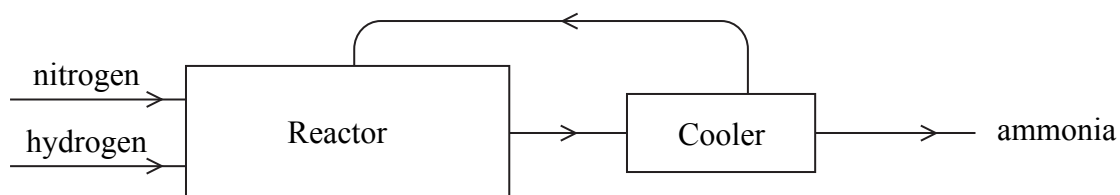

(a) State **three** conditions used in the reactor.

1

2

3

(3)

(b) What change of state does the ammonia undergo in the cooler?

.....

(1)

(c) Some of the ammonia formed in the Haber process is reacted with nitric acid to form ammonium nitrate.

(i) Write a chemical equation for this reaction.

.....

(2)

(ii) Give **one** major use of ammonium nitrate.

.....

(1)

(Total 7 marks)

Q1



2. Copper, iron and zinc can be reactants or products in displacement reactions. These metals have different reactivities.

The table shows the observations made when a student added a small amount of each metal to a solution of the sulphate of one of the other metals.

Experiment	Reagents	Observations
1	copper + iron(II) sulphate	no change
2	copper + zinc sulphate	no change
3	iron + copper(II) sulphate	solution turns from blue to pale green solid turns from dark grey to pink-brown
4	iron + zinc sulphate	no change
5	zinc + copper(II) sulphate	solution turns from blue to colourless solid turns from light grey to pink-brown
6	zinc + iron(II) sulphate	solution turns from pale green to colourless solid turns from light grey to dark grey

- (a) In Experiment 1, why was there no reaction?

.....

 (1)

- (b) In Experiment 3, which ion is responsible for the blue colour?

.....
 (1)

- (c) In Experiment 5, what is the pink-brown solid?

.....
 (1)

- (d) In Experiment 6, why does the solid turn from light grey to dark grey?

.....

 (1)



<p>(e) Which of the three metals is the most reactive?</p> <p>.....</p> <p style="text-align: right;">(1)</p> <p>(f) When preparing for these experiments, the student found a bottle labelled “iron sulphate solution”. To find out whether the solution contained iron(II) sulphate or iron(III) sulphate he tested it by adding sodium hydroxide solution.</p> <p>State the observation made, and identify the substance responsible for the observation, if the bottle contained iron(II) sulphate solution.</p> <p>Observation</p> <p>Substance responsible</p> <p style="text-align: right;">(2)</p> <p style="text-align: right;">(Total 7 marks)</p>	<p>Leave blank</p> <p>Q2</p> <div style="border: 1px solid black; width: 20px; height: 20px; margin: 0 auto;"></div>
Empty space for student answers	Empty space for marks



3. The formulae C_2H_6 and C_3H_8 represent two organic compounds.

(a) State why these compounds are described as

(i) hydrocarbons
 (1)

(ii) saturated
 (1)

(b) The compounds C_2H_6 and C_3H_8 are members of the same homologous series.

(i) What is the name of this homologous series?
 (1)

(ii) What is the general formula of this homologous series?
 (1)

(iii) Other than having the same general formula, state **two** other characteristics of members of the same homologous series.

1
 2 (2)

(c) The displayed formula of C_2H_6 is

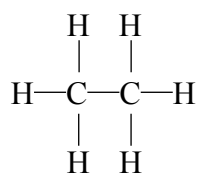

Draw the displayed formula of C_3H_8 .

(1)



Leave
blank

(d) Compounds with the molecular formula C_4H_{10} are also members of this homologous series.

There are two isomers with this molecular formula.

(i) What is meant by the term **isomers**?

.....
.....

(2)

(ii) Name **one** of these isomers and draw its displayed formula.

Name

Displayed formula

(2)

(e) Methane is another member of this homologous series.

Write a word equation for the complete combustion of methane.

.....
.....

(2)

Q3

(Total 13 marks)

7

Turn over



Leave blank

4. Salts can be made by neutralising acids.

For example, the salt magnesium sulphate is formed when magnesium, magnesium oxide, or magnesium carbonate is added to dilute sulphuric acid.

(a) Complete the table to show the equations and products for these methods of making magnesium sulphate.

Method	Equation	Names of products
1	$\text{Mg} + \text{H}_2\text{SO}_4 \rightarrow \text{MgSO}_4 + \dots\dots\dots$	magnesium sulphate and
2	$\text{MgO} + \text{H}_2\text{SO}_4 \rightarrow \text{MgSO}_4 + \text{H}_2\text{O}$	magnesium sulphate and water
3	$\text{MgCO}_3 + \text{H}_2\text{SO}_4 \rightarrow \text{MgSO}_4 + \dots\dots\dots + \dots\dots\dots$	magnesium sulphate and and

(5)

(b) State **one** observation that would be made when using methods 1 and 3, but not when using method 2.

.....

(1)

(c) A student showed the presence of sulphate ions in magnesium sulphate solution by adding dilute hydrochloric acid and barium chloride solution.

State the observation made and name the product responsible for the observation.

Observation

Name of product

(2)

Q4

(Total 8 marks)



BLANK PAGE

Turn over for Question 5



Leave blank

5. (a) Magnesium and fluorine react to form the ionic compound magnesium fluoride.

(i) The diagrams show the electron arrangement in an atom of magnesium and in an atom of fluorine.

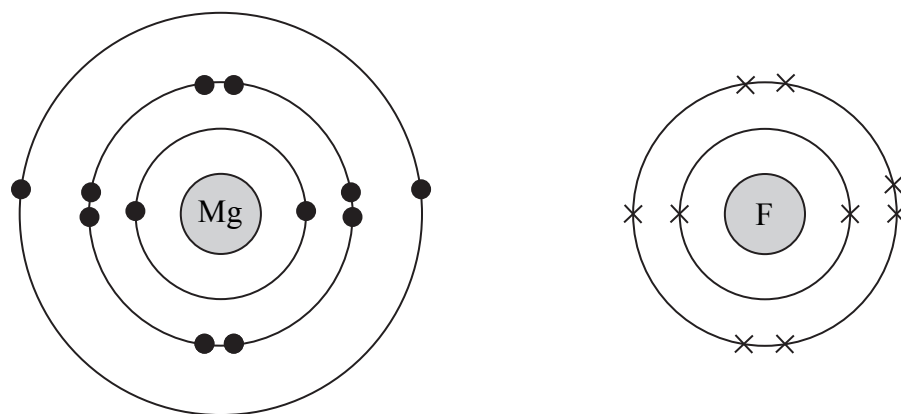

Describe what happens, in terms of electrons, when magnesium reacts with fluorine.

.....
.....
.....
.....
.....
.....

(3)

(ii) Give the formula of each of the ions in magnesium fluoride.

.....
.....

(2)



(b) The diagram shows apparatus for the electrolysis of lead(II) bromide.

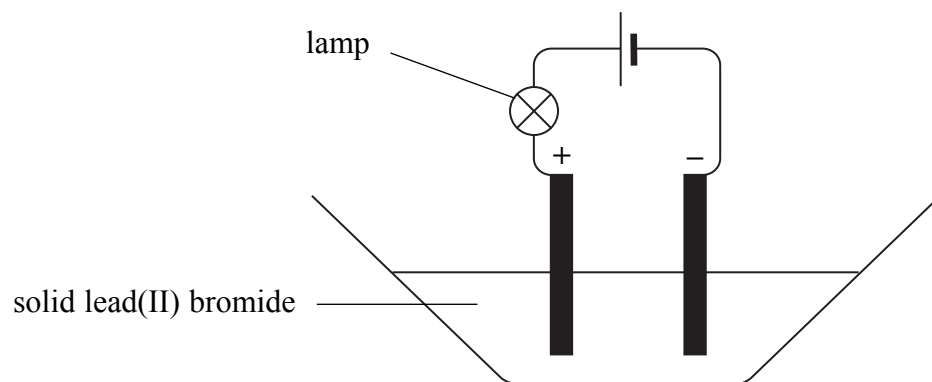

(i) Identify the non-metallic element used for both electrodes.

.....
(1)

(ii) When the apparatus is set up as shown, the lamp does not light.

State what must happen to the lead(II) bromide before the lamp will light.

.....
.....
(1)

(iii) When the lamp lights, electrolysis occurs and changes can be seen in the electrolyte.

Complete the table to show the substance responsible for the change and the electrode (+ or -) at which the substance is formed.

Observation	Substance	Electrode
Silvery liquid		
Brown gas		

(3)

Q5

(Total 10 marks)

TOTAL FOR SECTION A: 45 MARKS



BLANK PAGE



SECTION B

6. Copper(I) sulphide reacts with oxygen when heated in air.

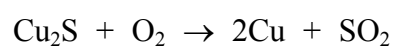

The copper produced by this reaction is impure.

(a) State **one** problem caused by releasing sulphur dioxide into the atmosphere.

.....
..... (1)

(b) Copper can be purified by electrolysis.
The impure copper is used as the positive electrode (anode).

(i) What is used as the negative electrode (cathode)?

..... (1)

(ii) Identify the solution used as the electrolyte.

..... (1)

(c) Give **one** use of copper and state the property of copper on which that use depends.

Use

Property

(2)



(d) Iron is obtained by reducing iron(III) oxide contained in haematite using a blast furnace.

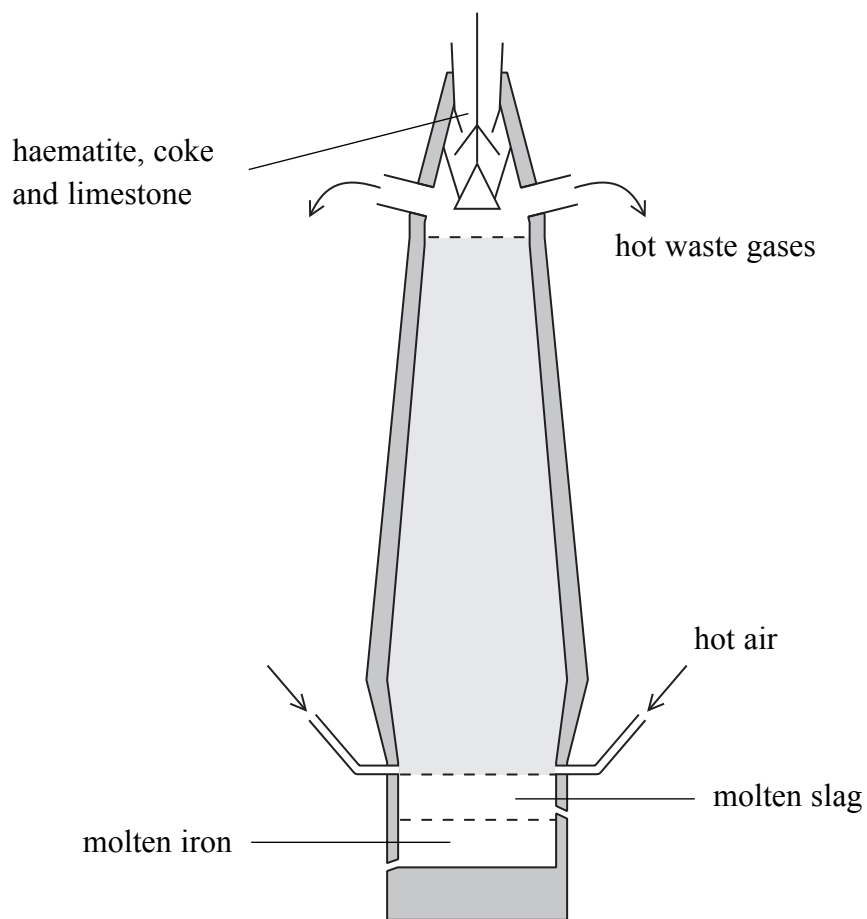

(i) Why is hot air blown into the bottom of the blast furnace?

.....
.....
.....

(2)

(ii) The haematite contains silicon dioxide as an impurity. The limestone is added to remove the silicon dioxide.

Explain how the limestone does this. You may use equations in your answer.

.....
.....
.....
.....
.....

(4)



(iii) One of the reactions that produces iron in the blast furnace is represented by the equation:

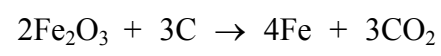

Using the equation, explain why this is called a **redox** reaction.

.....
.....
.....
.....

(2)

(Total 13 marks)

Leave
blank

Q6



7. A teacher adds a small piece of sodium to a large volume of water. He makes the following observations:

- the sodium melts
- the sodium slowly moves across the surface of the water
- there is fizzing.

(a) Rubidium is in the same group of the Periodic Table as sodium.

(i) Why do elements in the same group have similar chemical properties?

.....

 (1)

(ii) Write a chemical equation for the reaction of rubidium with water.

.....

 (2)

(iii) Compared to sodium, suggest **one** different observation that could be made when rubidium reacts with water.

.....
 (1)

(b) Complete the table about the atomic structures of sodium and rubidium.

Element	Atomic number	Mass number	Number of neutrons	Number of protons	Number of electrons
sodium	11		12	11	
rubidium	37	85		37	37

(3)



Leave blank

(c) A sample of rubidium contains two isotopes.

(i) What are isotopes?

.....
.....
.....

(2)

(ii) 72.2% of rubidium atoms in this sample have a mass number of 85.
All other rubidium atoms in this sample have a mass number of 87.

Calculate the relative atomic mass of rubidium.
Give your answer to one decimal place.

(3)

(d) Rubidium is a metal.

Explain, in terms of its bonding and structure, why rubidium is:

(i) a good conductor of electricity

.....
.....

(1)

(ii) malleable.

.....
.....
.....

(2)

(Total 15 marks)

Q7



BLANK PAGE



8. (a) Magnesium oxide reacts with water to form magnesium hydroxide.

(i) Write the chemical equation for this reaction.

.....

 (2)

(ii) Suggest the pH value of a solution of magnesium hydroxide.
 Explain your answer.

.....

 (2)

(b) Carbon dioxide can be prepared in the laboratory by reacting dilute hydrochloric acid with calcium carbonate.

(i) Write a chemical equation for this reaction.

.....

 (2)

(ii) Carbon dioxide reacts with water to form a weakly acidic solution.

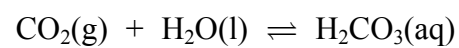

What is the name of the acid formed?

.....
 (1)

(iii) Magnesium oxide reacts with the acid formed in (b)(ii).
 One of the products is an insoluble white solid.

Suggest the identity of this solid.

.....
 (1)



(c) Magnesium oxide forms when magnesium burns in air.

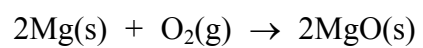

Describe what is observed when magnesium burns in air.

.....

.....

.....

(2)

(d) The following apparatus can be used to determine the percentage by volume of oxygen in the air.

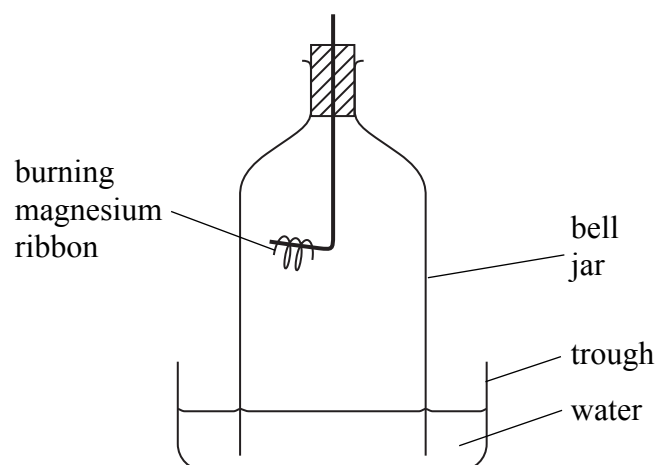

(i) What is the approximate percentage by volume of oxygen in the air?

.....

(1)

(ii) The volume of air in the bell jar at the start of the experiment is 5.0 dm³.

Use this volume and your answer to (d)(i) to calculate the amount, in moles, of oxygen molecules in the bell jar.
(The molar volume of a gas is 24 dm³.)

(2)



(iii) Calculate the amount, in moles, of magnesium needed to react with this amount of oxygen.

Leave blank

(1)

(iv) Calculate the minimum mass, in grams, of magnesium needed to react with all the oxygen in the bell jar.

(2)

Q8

(Total 16 marks)

21

Turn over



BLANK PAGE



9. Crude oil is a complex mixture of hydrocarbons. It is separated into fractions by fractional distillation. The diagram shows a fractionating tower.

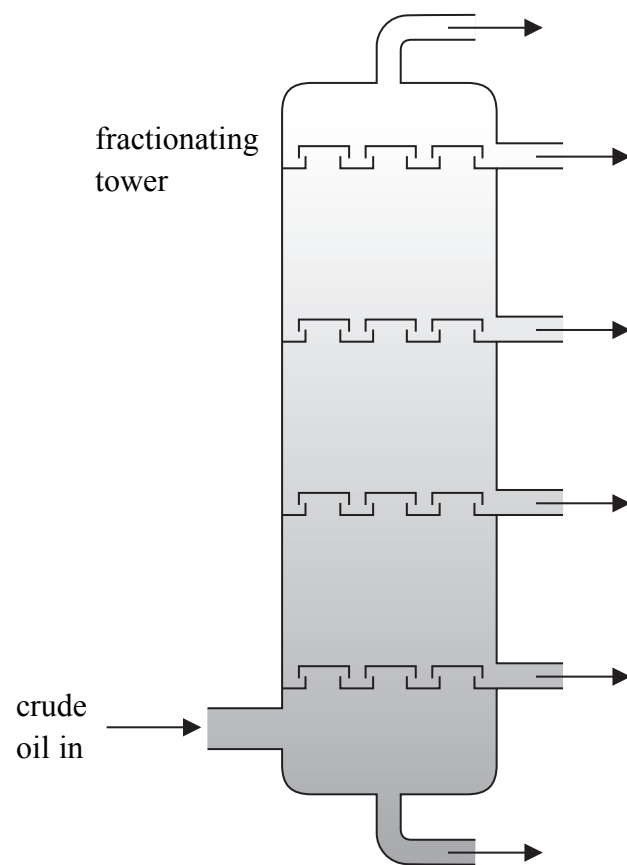

- (a) Describe how crude oil is separated into fractions.

.....

.....

.....

.....

.....

.....

.....

(3)



(b) Some fractions containing long-chain hydrocarbons are cracked.

- (i) During cracking, a hydrocarbon with the formula $C_{20}H_{42}$ produces only two products. One of the products is an alkene.

Complete the following equation:

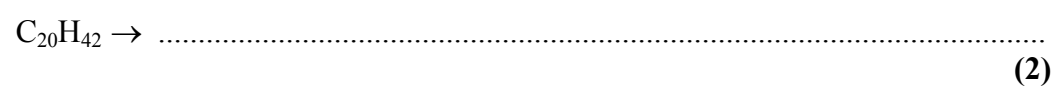

- (ii) Give **two** reasons why it is economically important to crack long-chain hydrocarbons.

.....

 (2)

(c) Alkenes can form addition polymers.

- (i) Draw the repeat unit of the addition polymer formed by propene, $CH_3CH=CH_2$.

(2)

- (ii) Another addition polymer has the structure

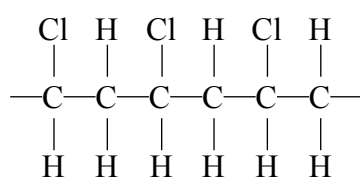

Name and draw the displayed formula of the alkene that forms this polymer.

Name

Displayed formula

(2)



Leave
blank

(d) Nylon is a different type of polymer. It can be made using the monomers

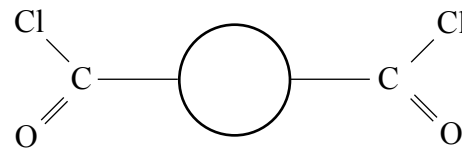
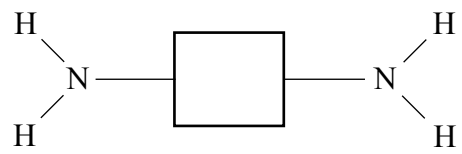

(i) What type of polymer is nylon?

..... (1)

(ii) Draw the repeat unit of the nylon formed from these monomers.

(3)

(iii) Identify the gas produced when nylon is formed from the monomers shown.

..... (1)

(Total 16 marks)

Q9



BLANK PAGE



10. Ammonia is a covalent compound with a simple molecular structure.
It is a gas at room temperature.

(a) Explain why ammonia has a low boiling point.

.....
.....
.....
.....
.....

(3)

(b) Ammonia reacts with iodine.

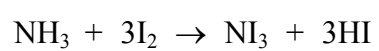

Hydrogen iodide, HI, is given off as a gas; it is very similar to hydrogen chloride.

Suggest what is seen when hydrogen iodide reacts with sodium carbonate solution.

.....
.....

(1)



(c) Nitrogen triiodide, NI_3 , readily decomposes

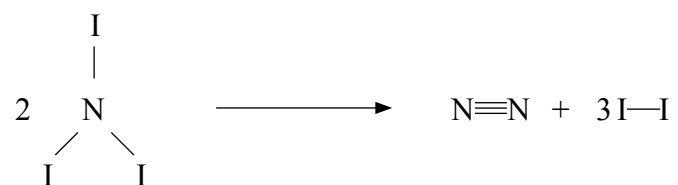

The table shows the values of some average bond dissociation energies.

Bond	N—I	N≡N	I—I
Dissociation energy (kJ/mol)	169	944	151

Use these values to calculate:

(i) the energy needed to break all the bonds in the reactants

(2)

(ii) the energy given out when making all the bonds in the products

(2)

(iii) the enthalpy change for the decomposition.

(1)



Leave
blank

(d) (i) Draw a dot and cross diagram to show the bonding in a nitrogen molecule.

(2)

(ii) How do the shared pairs of electrons hold the nitrogen molecule together?

.....
.....
.....

(1)

(e) Ammonia reacts with phosphoric acid to form a compound that contains 28.2% nitrogen, 8.1% hydrogen, 20.8% phosphorus and 42.9% oxygen by mass.

Calculate the empirical formula of this compound.

(3)

Q10

(Total 15 marks)

TOTAL FOR SECTION B: 75 MARKS

TOTAL FOR PAPER: 120 MARKS

END

29



BLANK PAGE



BLANK PAGE



BLANK PAGE

